

# REYNOLDS®

model 17E10.5LGP

**LGP** Low Ground Pressure

high flotation special application **SCRAPERS**



## sand & wet material moving with agricultural tractors

### productive

■ LGP scrapers are self loading to excavate, transport and spread material with minimum rolling resistance and power requirements.

### Reliable

■ Two 43" (1,09m) wide super flotation tires eliminate mud build-up between side walls. Reduced tire rutting improves equipment ground speed.

### Operation

■ Reliable hydraulic controls. Mult-function manifold block. Tubing with 37° flare.

*"America's Preferred Scraper"*

# REYNOLDS®

REYNOLDS INTERNATIONAL EQUIPMENT, L.P.  
P.O. Box 550, McAllen, Texas 78505-0550 USA  
[www.reynoldsinternational.com](http://www.reynoldsinternational.com)

# REYNOLDS

## model 17E10.5LGP 17 yd.<sup>3</sup> (13 m<sup>3</sup>) EJECTOR Scraper

### Specifications

■ **capacities** 17 yd<sup>3</sup> (13.0 m<sup>3</sup>) heaped

17.0 yd<sup>3</sup> (10.6 m<sup>3</sup>) struck

■ **bucket dimensions**

W 126" (3.20m), L 96" (2.43m),

H 55" (1.39m)

■ **transport dimensions**

W 144" (3.65m), L 266" (6.75m),

H 81" (2.05m), Clearance. 20" (0.50m)

■ **tires**

(2) flotation tires 66 x 43-25

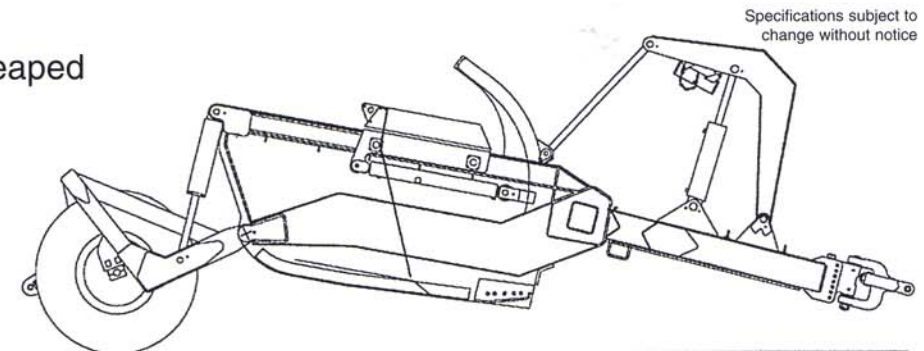

■ **shipping weight est.**

23,800 lb (10,818 kg)



### Features

Multi-Function Valve Block.

Greasable pins, roller bearings.

Safety blocks for hydraulic cylinders

Height adjustable yoke hitch.

Rear lights.

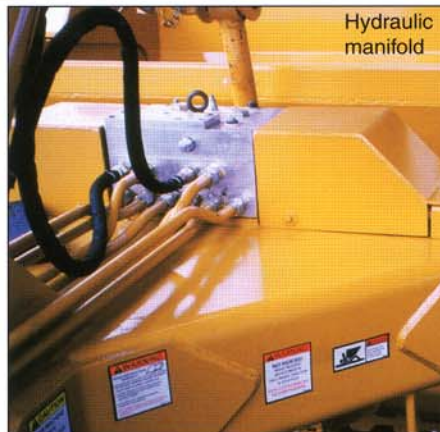

### Options

Laser receiver mount bracket.

Tractor draw bars.

### Tractor requirements

■ **hydraulics**

two double acting circuits

optimum 25 GPM (100 l/min)

at 2500 PSI (175 bar)

■ **engine HP range**

one scraper: 300-400 HP



**REYNOLDS INTERNATIONAL EQUIPMENT, L.P., P.O. Box 550, McAllen, Texas 78505-0550 USA**

Tel. (956) 687-7500, Fax (956) 687-3082, E mail: info@reynoldsinternational.com