

REYNOLDS®

Ejector SCRAPER 14E10.5

***Fast Loading**

***Very Reliable**

***Easy to Move**



Patented "SDS" hydraulic system synchronizes the displacement on the ejector and gate for precise material volume control in the bucket.

3-piece BORON STEEL cutting blade with a center stinger makes it easy to load the bucket. A reversible, serrated Boron steel stinger blade is standard.



Serrated Center Blade

"America's Preferred Scraper"

REYNOLDS®

REYNOLDS INTERNATIONAL EQUIPMENT, L.P.
P.O. Box 550, McAllen, Texas 78505-0550 USA
www.reynoldsinternational.com



Ejector SCRAPER

for Contractors & Farmers

Specifications model	capacity		width		tires	shipping	Price Quote
	struck	heaped	cutting	transp.	4	weight	
14E10.5	10.6 yd³ (8,0 m ³)	14.0 yd³ (10,6 m ³)	126" (3,20 m)	143" (3,63 m)	17.5 x 25	19,000 lb (8,636 Kg)	

Standard Features

- Height adjustable yoke hitch.
- Tandem hydraulics and rear hitch.
- Tires 17.5 x 25.
- Safety stops and transport locks.
- Laser receiver mounting plate.



Specifications subject to change without notice

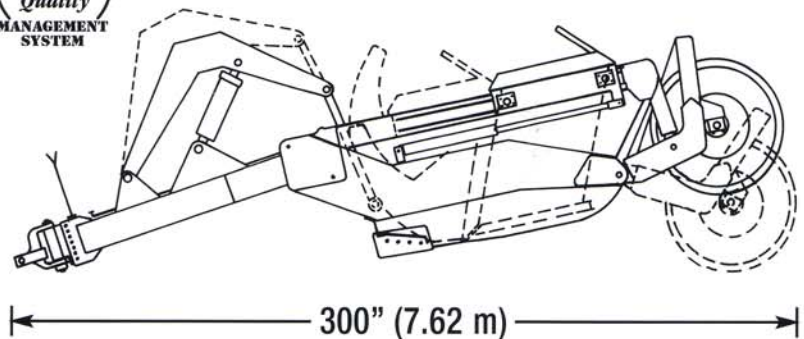

Options

- Drawbar for the tractor.
- Plain center blade for laser leveling.

Tractor requirements

- **hydraulics** 25 GPM (100 l/min) at 2500 PSI (175 bar) optimum
- **engine HP recommendation** 250-300 HP



Model 14E10.5

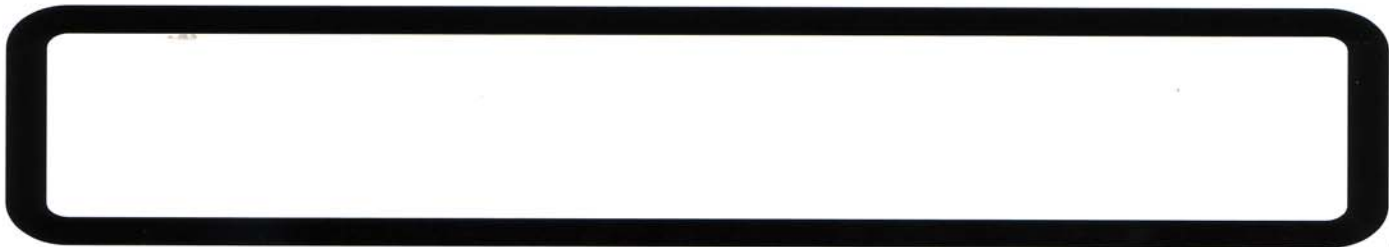

REYNOLDS INTERNATIONAL EQUIPMENT, L.P., P.O. Box 550, McAllen, Texas 78505-0550 USA
 Tel. (956) 687-7500, Fax (956) 687-3082, E mail: info@reynoldsinternational.com